

09/16/12-16:53 PATH: DHW-17v15

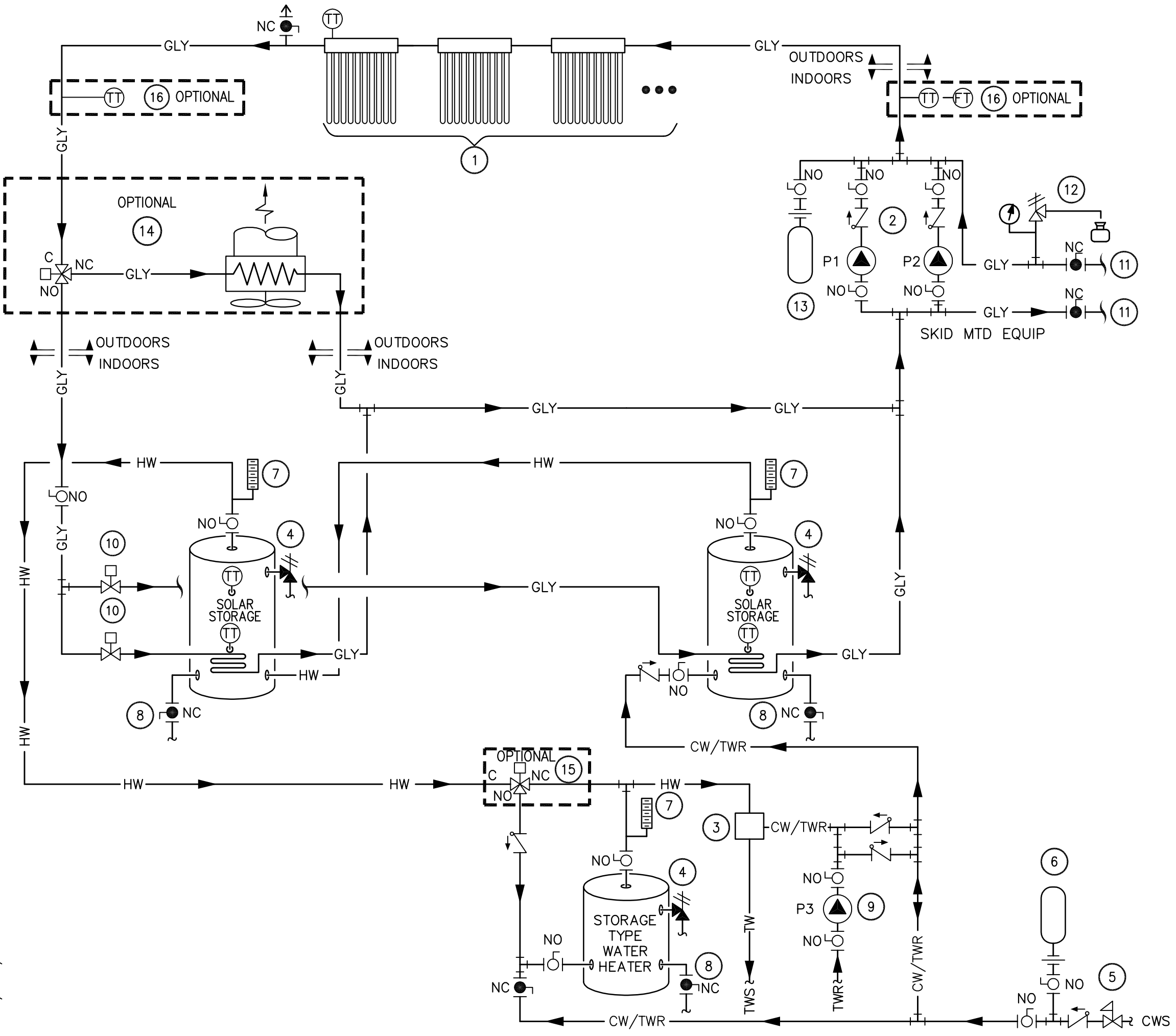

GENERAL NOTE :

1. ADD ISOLATION VALVES AND UNIONS AS NEEDED.

KEYED NOTES :

- ① INSTALL KINGSPAN, HP-450 SOLAR COLLECTORS IN SERIES UP TO 6 UNITS. FOR MULTIPLE ROW SYSTEMS REFER TO SOLAR ARRAY FLOW DIAGRAM, DHW-10.
- ② SOLAR CONTROL AND PUMP STATION. CONNECT TO ALL TRANSMITTERS (TT) & (FT), OPTIONAL HEAT DISSIPATER (14) AND VALVE ACTUATORS (10).
- ③ MIXING VALVE (SEE MIXING VALVE DETAIL DHW-0)
- ④ ROUTE T&P RELIEF VALVE (PRESSURE RELIEF ONLY FOR SOLAR STORAGE TANKS) DISCHARGE, FULL SIZE, TO FLOOR DRAIN.
- ⑤ PRESSURE REDUCING VALVE - INSTALL ONLY IF WATER SUPPLY PRESSURE EXCEEDS 75% OF WATER HEATING SYSTEM DESIGN PRESSURE.
- ⑥ ASME THERMAL EXPANSION TANK - SIZE ACCORDING TO MANUFACTURER'S RECOMMENDATION.
- ⑦ COMBINATION TEMPERATURE AND PRESSURE GAUGE. INSTALL WITHIN 12" OF HOT WATER OUTLET.
- ⑧ PROVIDE FULL-PORT DRAIN VALVE AND ROUTE TO FLOOR DRAIN.
- ⑨ RECIRCULATION PUMP. PROVIDE AQUASTAT ONLY IF REQUIRED BY CODE WITH LETTER TO OWNER REQUIRING RELEASE OF LIABILITY (NON-MOVING WATER PROMOTES LEGIONELLA).
- ⑩ ACTUATOR VALVES FOR TANK PRIORITY.
- ⑪ PROVIDE 1/2" CHARGE AND PURGE VALVES FOR GLYCOL LOOP.
- ⑫ PROVIDE 100 PSI PRESSURE GAUGE AND PRESSURE RELIEF VALVE (87 PSI) CONNECTED TO A CONTAINER.
- ⑬ EXPANSION TANK SIZED FOR GLYCOL LOOP.
- ⑭ FAN COIL UNIT, SIZED TO DISCHARGE AT LEAST 5,000 BTUH PER COLLECTOR. 3 PORT VALVE TO DIVERT COLLECTOR RETURN AWAY FROM STORAGE TANKS TO DISSIPATER AND ACTIVATE HEAT DISSIPATER FAN WHEN COLLECTOR REACHES 230 DEG F.
- ⑮ 3-WAY VALVE DIVERTS HOT WATER FROM SOLAR STORAGE TANK DIRECTLY TO MIXING VALVE WHEN TEMPERATURE IS 160 DEG F OR HIGHER.
- ⑯ TEMPERATURE AND FLOW TRANSMITTERS TO MONITOR ENERGY PRODUCTION

RAND ASSOCIATES INCORPORATED	
Domestic Hot Water Flow Diagram Water Heater with Dual Solar Storage Glycol Solar Loop	
PIPING DIAGRAM	Size: B FSCM No: - Drawing No: DHW-17 Version: 15 Drawn By: BLW Scale: NONE Date: 09.15.2012 Sheet: 1 of 1